

## Key Features

- Pre-assembled kit, ready for immediate use—no installation required
- Foldable screen that fits easily into large passenger elevators for convenient transport
- Shockproof, dustproof, and moisture-resistant with GOB surface treatment
- Built-in stand with an integrated control box and motorized height adjustment
- Seamless large display designed to captivate audiences in any space



## Product Description

The ViewSonic® LDS138-151 is a foldable 138" All-in-One LED display that provides instant use, easy transport, and convenient operation. With a pre-assembled design and built-in motorized height adjustment, this display can be set up in just 10 minutes without wall mounting, making it ideal for large venues or spaces where renovations are not feasible. The foldable screen design significantly reduces packaging size, cutting shipping costs, improving delivery efficiency, and enabling easy transport between locations. The integrated system control box on the floor stand ensures tidy cable management and a premium, frameless visual experience. Featuring Glue-on-Board (GOB) surface treatment technology, the IP54-rated LED modules offer enhanced protection against impacts, dust, and moisture during installation and use. With its seamless large screen and dual 30W speakers, the LDS138-151 is ready to captivate audiences in environments such as high-end boardrooms, receptions, galleries, auditoriums, and other large venues.

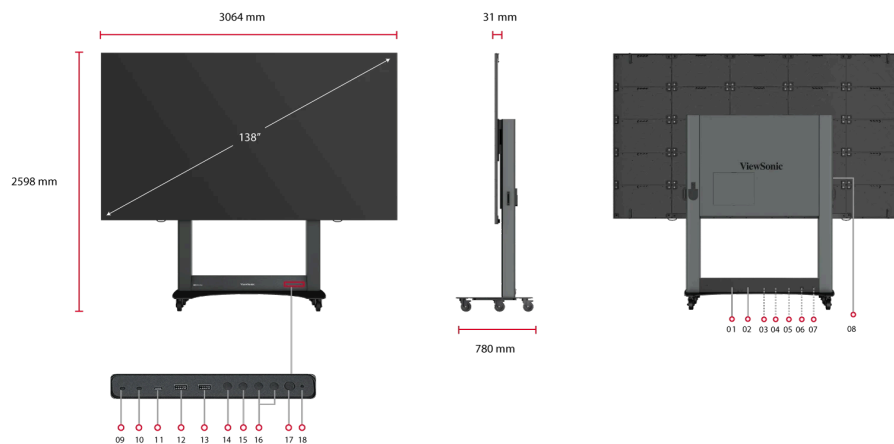

## SPECIFICATION

Screen Size:	138"
Display Area (mm):	3050 (H) x 1715(V)
Native Resolution:	1920x1080
Panel Technology:	Direct view LED
LED Package Type:	SMD 3 in 1 (GOB)
Bonding Wire:	Copper
Pixel Pitch (mm):	1.588
Brightness (max.):	600 nits (100 levels adjustable)
Contrast Ratio (typ.):	6500:1
Color Temperature:	3000K -10000K
Orientation:	Landscape
Viewing Angles (typ.):	H = 170, V = 170
LED Lifetime (typ.):	100,000 Hours
Local Storage:	Total 32GB (26GB available storage)
Embedded OS:	Android 9.0
Resolution Support:	VGA(640 x 480) to 4K(3840 x 2160@60hz)
HDTV Compatibility:	480p, 576p, 720p, 1080p, 2160p
Horizontal Frequency:	31K-94kHz
Vertical Scan Rate:	56-85Hz

## INPUT

HDMI:	4 (HDMI 2.0/HDCP 2.2) (internal x3, external x1)
USB Type A:	3 (USB3.0 x1, USB2.0 x2)
RJ45 Input:	3 (internet x2, control x1)
IR in (3.5mm):	1
Wi-Fi Input:	2.4G/5G Hz
USB Type C:	1 (data only)

## OUTPUT

HDMI out:	1 (HDMI 1.4/HDCP 1.4) (internal x1)
Speaker:	30Wx2
Audio out (3.5mm):	2
S/PDIF:	1
USB Type A (Power):	Shared with USB A input (USB 3.0 5V/0.9A x1, USB 2.0 5V/0.5A x1, USB 2.0 5V/2A x1)
USB Type C (Power):	Shared with USB Type C input (5V/1A x1)

## CONTROL

RJ45 (LAN control):	1(shared with internet)
USB Type A (Services):	1(shared with USB A input)
RS232 (DB 9-pin female):	1
IR Receiver:	1

## OTHERS

Power Supply Voltage:	100-240V ~ 50/60Hz (vary by country)
Power Consumption (W/unit):	581W (typ), 1745W (max) < 0.5W (Hibernate) Inrush Current: 220V: 84A / 110V: 58A
Operating Temperature:	0~40°C
Total LED Module Quantity:	200
Ingress Protection Rating:	IP54(Front)
Impact Protection Rating:	IK06(Front)
Net Weight:	511.16 lbs (250 kg)
Gross Weight:	919.33 lbs (417 kg)
Product Dimensions (WxHxD):	1850.81x1948.4x780mm(min.) 3064x2598x780 mm(max.)
Packing Dimensions (WxHxD):	81.5x78.58x33.35 inches (2070x1996x847 mm)

## STANDARD ACCESSORIES

Power Cord:	1
LAN Cable (Cat 5E):	1
IR Extender Cable:	1
Remote Control:	1
QSG:	1
Spare Parts:	LED module x14 3 in 1 hub board x3
Maintenance Tool:	LD-MK-006 x1

## OPTIONAL ACCESSORIES

Maintenance Tool:	LD-MK-006
-------------------	-----------